

## TO THE OWNER OR USER:

---

The service manual you are reading is intended to provide you, and the maintenance or service technician, with the information needed to install, start up, clean, maintain and service this ice system.

The FM2402RH (remote high side) is the freezer portion of a commercial ice machine. It is designed to be connected to the condensing section of a refrigeration system, specifically a supermarket R-22 system. It consists of two evaporators, two

garmotors, two liquid line valves, two control boxes, two thermostatic expansion valves, and an EPR valve.

For the Installer . . . . .	Page 2
For the Electrician . . . . .	Page 4
For the Plumber . . . . .	Page 5
Final Check List . . . . .	Page 6
Initial Start Up . . . . .	Page 7
Component Identification . . . . .	Page 8
Electrical Sequence . . . . .	Page 11
Operation . . . . .	Page 12
Maintenance and Cleaning . . . . .	Page 14
Service Diagnosis . . . . .	Page 17
Removal and Replacement	
Bin Controls and Reservoir . . . . .	Page 20
Bearing and Breaker . . . . .	Page 21
Auger . . . . .	Page 22
Water Seal . . . . .	Page 23
Evaporator . . . . .	Page 24
Gearmotor . . . . .	Page 25
Circuit Board Tester . . . . .	Page 26

***Parts lists and wiring diagrams are in the center of this manual, printed on yellow paper.***

# FM2402RH

## FOR THE INSTALLER: Specifications

The FM2402RH is designed to fit several Scotsman storage bins. In some cases a bin top kit will be required.

and performance. They meet or exceed the standards of U.L., N.S.F., and C.S.A.

Scotsman assumes no liability or responsibility of any kind for products manufactured by Scotsman that have been altered in any way, including the use of any parts and/or other components not

**Installation Limitations:** The FM2402RH is

**BACK VIEW**

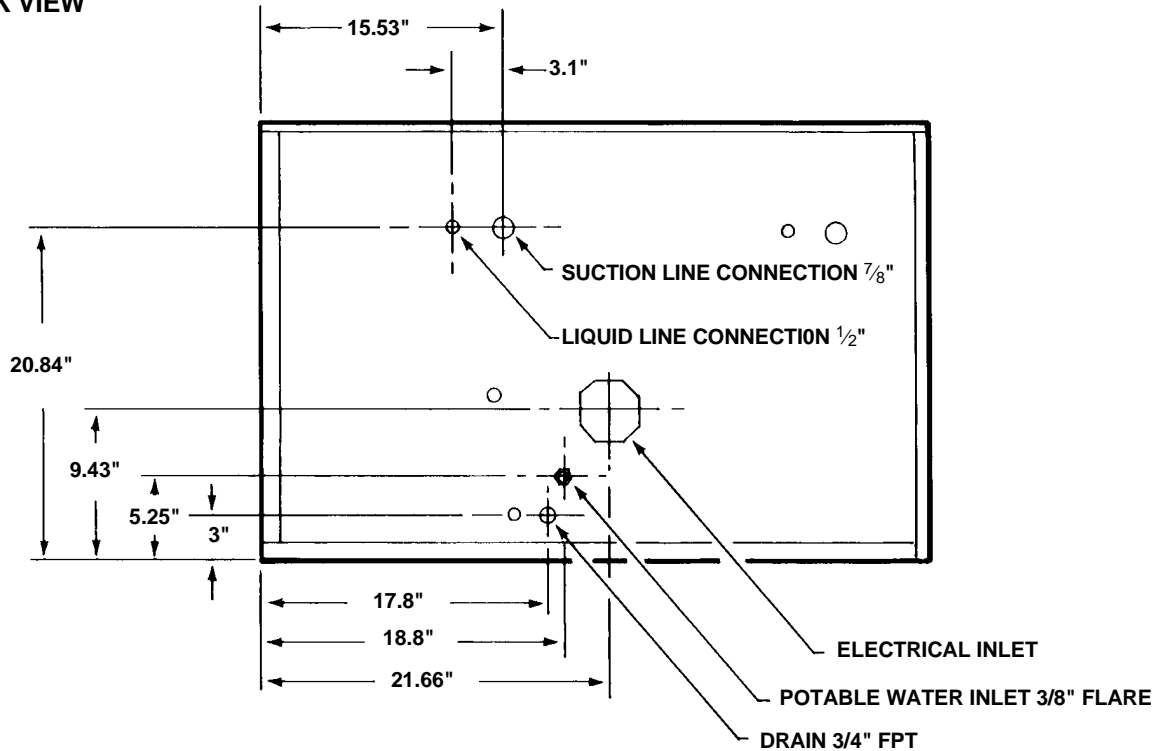

designed for indoor installations only. The machine must also be in a controlled environment where the air temperature does not fall below 50°F., or go above 100°F.

The water temperature must be between 40°F. and 100°F.

The electrical power supply must not drop below -5% of the lowest nameplate voltage or go above 10% of the highest nameplate voltage.

### SPECIFICATIONS:

Scotsman Ice Systems are designed and manufactured with the highest regard for safety

specifically approved by Scotsman.

Scotsman reserves the right to make design changes and/or improvements at any time. Specifications and designs are subject to change without notice.

Model Number	Dimensions (w/o Bin) H" x W" D"	Ice Type	Basic Electrical	Minimum Circuit Ampacity	Maximum Fuse Size	BTU's Required
FM2402RH-32A	27" X 42" X 24"	Flake	208-230/60/1	2.7	15	16,000

## FOR THE INSTALLER

### Select the Location:

The unit can only be installed indoors within the limitations described on page 2.

The ice machine will have to be connected to the buildings R-22 refrigeration system, check to be sure that the system has enough extra capacity to handle a minimum of additional 16,000 BTU's per hour @ 110°F. liquid line temperature. Assume a 0°F. evaporator temperature.

### Storage Bin:

Scotsman's B90 will be the presumed bin of choice. If using the bin extension, install heavy duty leg kit KLP4 and place the bin into position.

Remove the paper tape from the bin edge gasket, and install the bin extension onto the B90.

Remove the paper tape from the bin extension top edge, and using a mechanical lift, install the FM2402RH onto the top of the storage bin assembly.

Fasten the ice machine to the bin using (4) 5/15-18 2.5" cap screws.

Level the assembly by:

- Turning the leg levelers in or out on the standard legs.
- Use shims under the heavy duty legs of the KLP4.

**Locate the Nameplate:** The nameplate is located on the back panel of the machine, and contains the electrical characteristics particular to the unit being installed.

### Refrigeration Installation:

The skills of a refrigeration technician are required to connect the ice machine to the buildings refrigeration system.

### TYPICAL INSTALLATION: ALLOW ROOM FOR SERVICE ACCESS

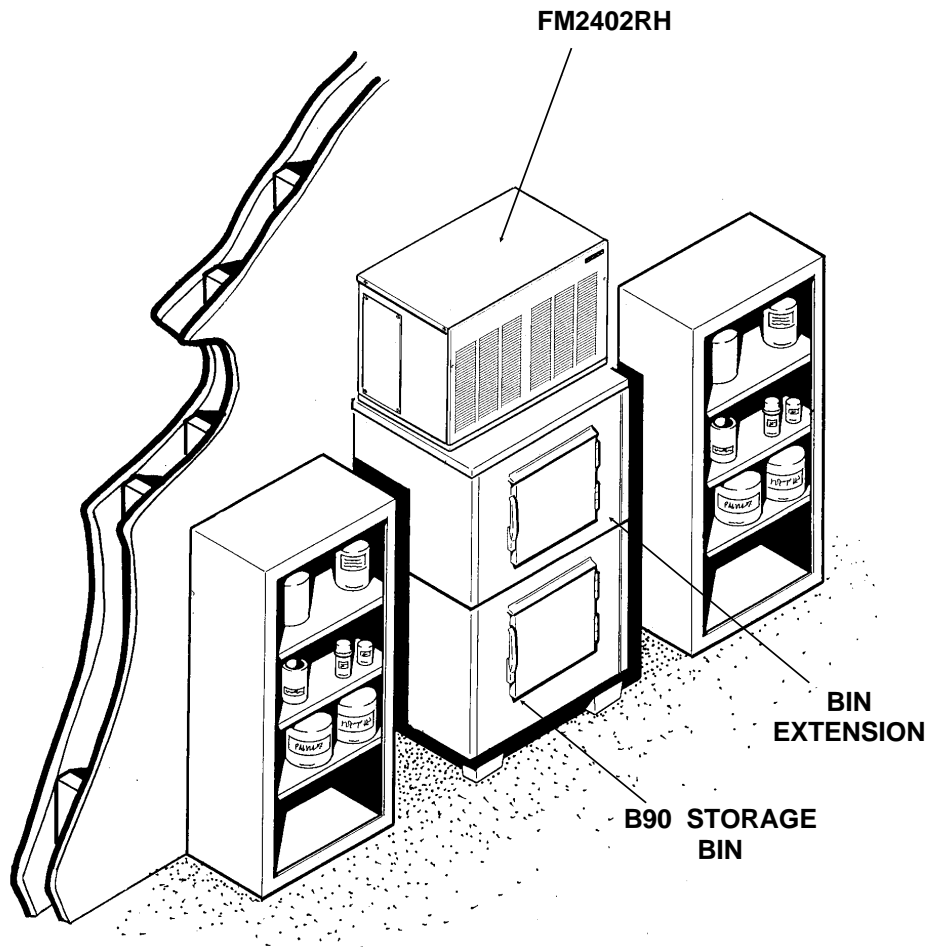

////////////////////////////////////Caution////////////////////////////////////

Connect to a R-22 system only.

////////////////////////////////////

Local Codes must be observed.

A P-trap should be installed where there will be more than 10' of vertical rise in the suction line.

# FM2402RH

## FOR THE ELECTRICIAN

### CONFORM TO ALL APPLICABLE CODES

#### Electrical Connections:

Locate the nameplate for the current requirements, and then determine the wire size and type per the National Electric Code. The machine requires a solid chassis to earth ground wire. Refer to the wiring diagram. The ice machine should be connected to its own electrical circuit, and be individually fused.

Voltage, when the unit is under full load, must remain within the limitations listed on page 2.

**LOW VOLTAGE CAN CAUSE  
EQUIPMENT MALFUNCTION  
AND/OR DAMAGE**

All external wiring should conform to the National, State, and local electrical codes. Usually the services of a licensed electrician will be required.

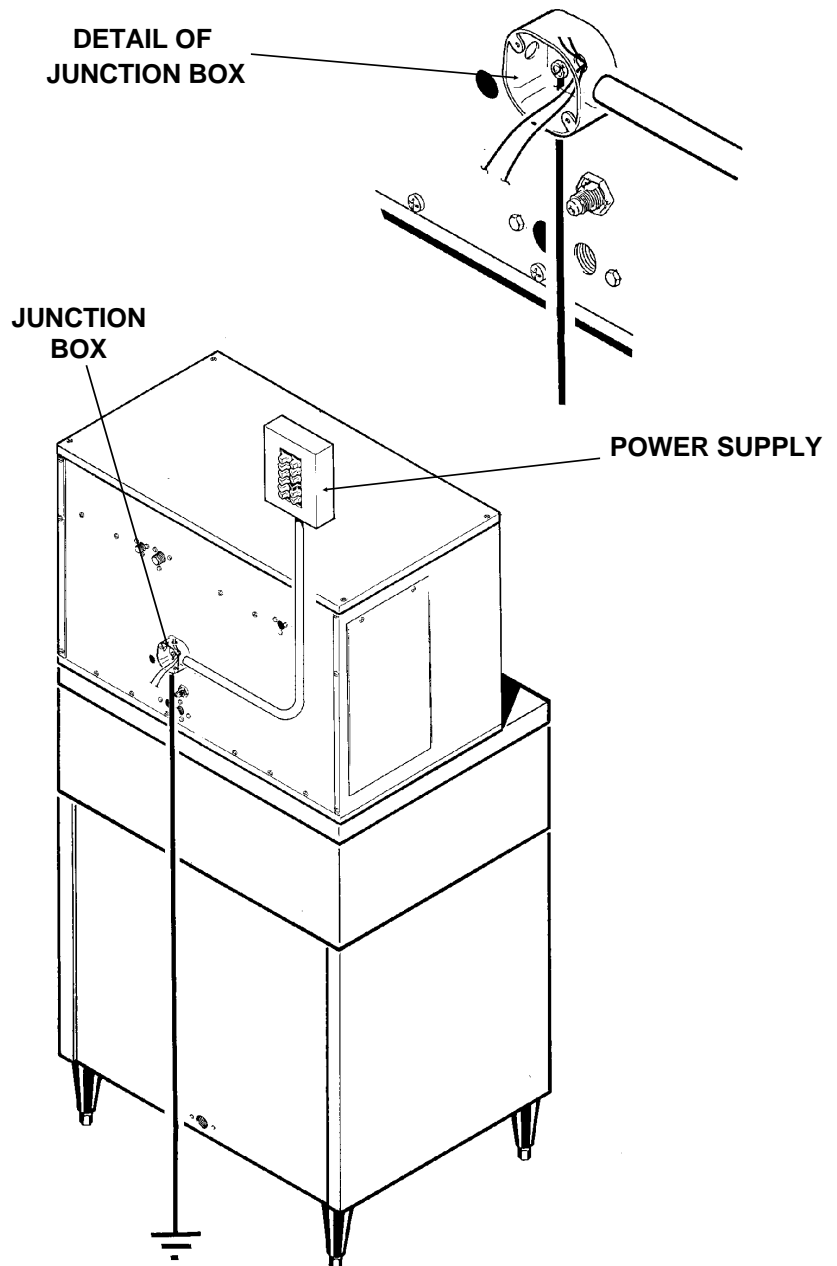

## FOR THE PLUMBER

### CONFORM TO ALL APPLICABLE CODES

#### Water Supply:

The recommended water supply line is 3/8" O.D. copper tubing, with a minimum operation pressure of 20 PSIG, and a maximum of 120 PSIG. Connect to cold water using the male flare connection at the back of the machine. Install a shut off valve in an accessible space between the ice maker and the water supply.

All drains are of the gravity type, and must have a minimum of 1/4" fall per foot of horizontal run. The drains must be installed to conform to local plumbing codes. The use of a vent at the machine and at the bin will allow the system to drain properly. Use only rigid tubing for drains; insulation of the bin drain is recommended.

#### Drain System:

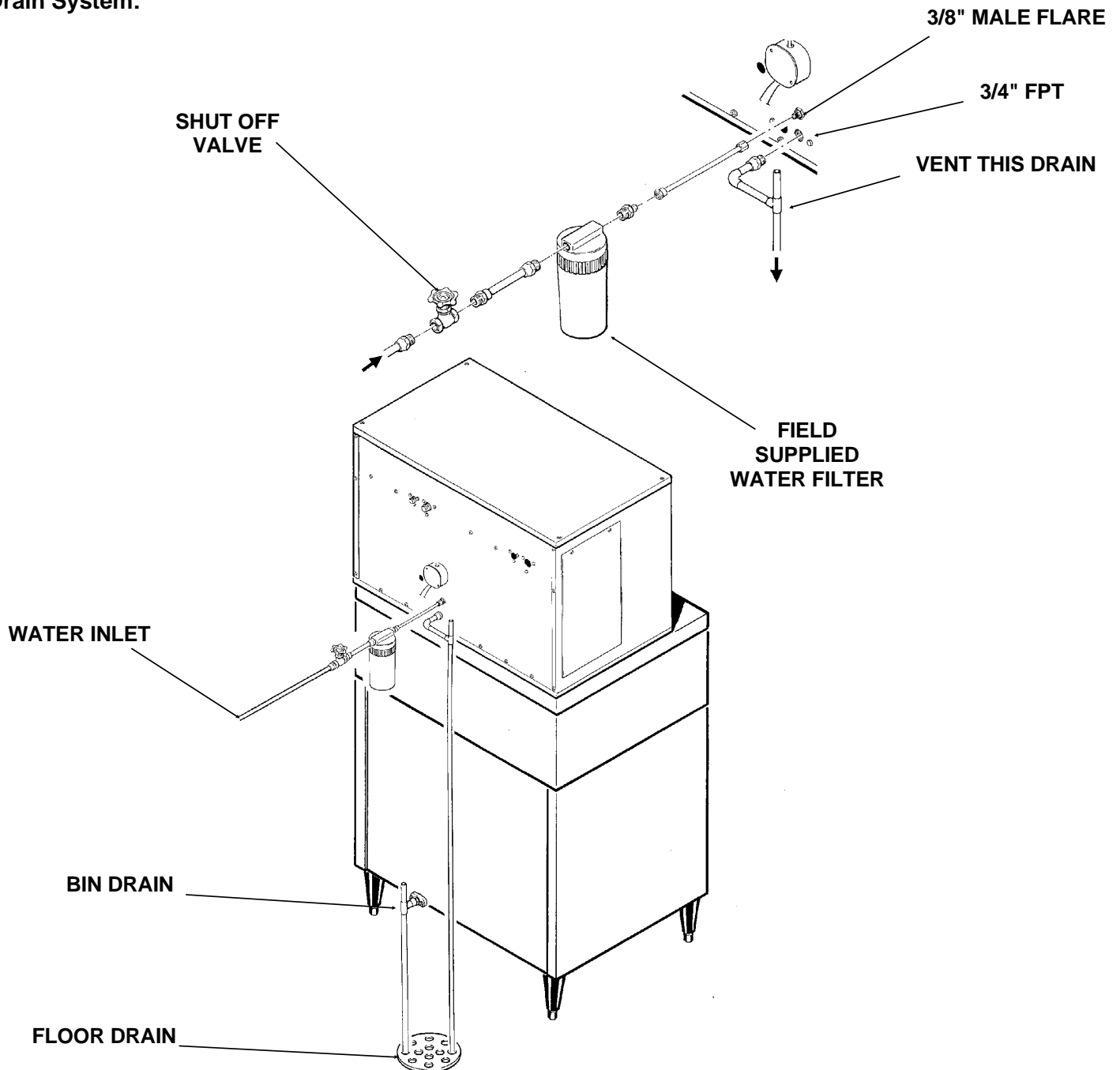

# FM2402RH

## FOR THE INSTALLER: Final Check List

---

1. Is the unit installed where the air and water temperatures are within and will remain within the limitations for the unit?

2. Is there 6" clearance at the rear of the machine for utility connections?

3. Has the water supply line be checked for pressures between 20 and 120?

4. Has the unit been leveled?

5. Has the shipping material been removed from inside the cabinet?

6. Have the electrical connections been made?

7. Have the drains been installed and checked for leaks?

8. Has the refrigeration supply been installed and checked for leaks?

9. Has the bin and cabinet been wiped clean or sanitized?

10. Has the warranty registration card been properly filled out and mailed to Scotsman?

11. Has the owner been given the service manual and been instructed on how to maintain the icemaker?

13. Has the owner been given the name and telephone number of the local Scotsman service agency?

## INITIAL START UP

---

1. Remove the top and front panels.
2. Open the water valve, and observe that the two float reservoirs fill up with water and shut off.
3. Switch on the electrical power.
4. Open the hand valves (in the liquid lines).
5. Open the ball valves (in the suction lines).
6. Switch on one master switch, and observe:
  - The liquid line valve opens
  - The gearmotor runs
  - Within a short time, that side of the machine begins to make ice.
  - Water flows from the water reservoir, and the float drops, letting in more water.
7. Switch on the other master switch, observe that:
  - The liquid line valve opens
  - The gearmotor runs
  - Within a short time, that side of the machine begins to make ice.
  - Water flows from the water reservoir, and the float drops, letting in more water.
8. With both sides operating, the sight glass should remain full, and the low side pressure will be about 24 psig, + or - 2 psig. Gearmotor amp draw should not exceed the nameplate rating.
9. Check the system very carefully for any refrigerant leaks, repair as needed.

# FM2402RH

## COMPONENT IDENTIFICATION

### Liquid line valve(s)

These valves operate to turn the ice making process on and off.

When the ice level drops in the ice chute, the ice level sensor will cause the circuit board to close the liquid line relay, which energizes the liquid line valve for that side of the system. The liquid line valve opens, and liquid refrigerant flows to the thermostatic expansion valve.

### Thermostatic Expansion Valve

The metering device of each system, the valve(s) sense the temperature of the suction line and vary the amount of liquid refrigerant that passes through the valve into the evaporator, thus maintaining a constant level of refrigeration. TXV's are factory set. Do not adjust unnecessarily.

**DO NOT ADJUST THE TXV UNTIL THE EPR HAS BEEN SET.**

The superheat setting is 4-8<sup>0</sup>F. Measure the temperature of the evaporator outlet at the TXV bulb, and check the low side pressure at the EPR valve (about 24 PSIG). Convert the pressure to temperature (using a temperature pressure chart) and subtract the amount from the outlet

temperature. The result is the superheat. Use an electronic thermometer.

### EPR: Evaporator Pressure Regulator Valve

This valve maintains a constant pressure on it's inlet (evaporators) side regardless of the pressure on the outlet (suction) side. The EPR is factory set, adjust only if needed. After adjusting check TXV superheat.

### Evaporators:

Where the water is frozen into ice crystals. As the water cools, it begins to turn into ice, and the slowly turning auger lifts the ice, as it is being made, and forces it up and out of the "breaker" or spout where the extra water is compressed out of the ice. The ice then drops through the chute, into the storage bin.

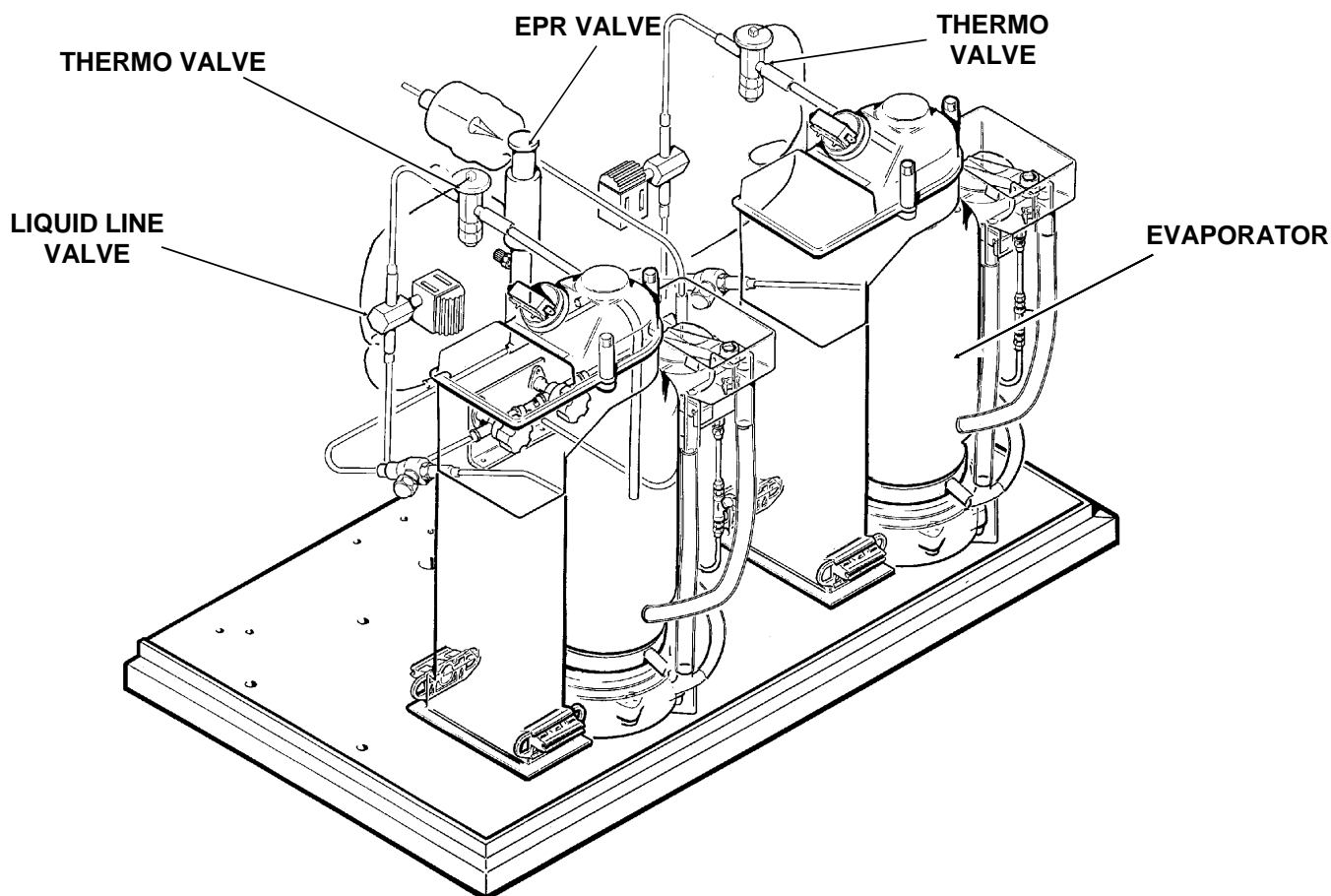



## COMPONENT DESCRIPTION: Control Box

---

**Circuit Board:** Controlling the ice machine through sensors and relays. The sensors are: ice level, and water level. The relays are for the gear motor (with a built in time delay to clear the evaporator of ice when the unit turns off) and for the liquid line valve.

**Transformer:** Supplies low voltage to the circuit board.

**On/Off Switch:** Manual control for that side of the machine.

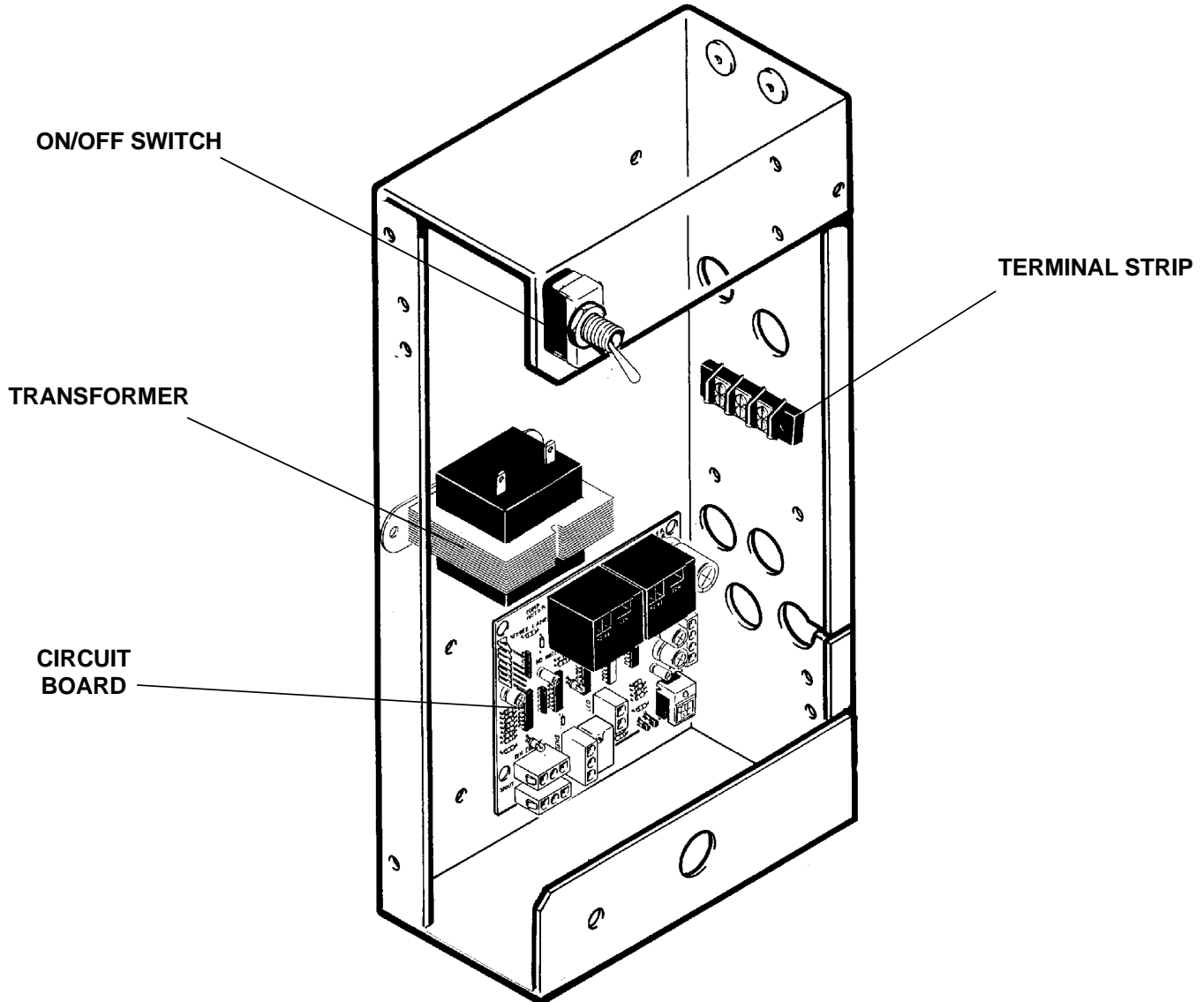

# FM2402RH

## COMPONENT DESCRIPTION: Evaporator

**Evaporator:** A refrigerated vertical tube filled with water and containing a water seal and auger.

**Auger:** A solid stainless steel double spiral auger, it pushes the ice crystals up to the top of the evaporator.

**Water Seal:** A two part "face" seal, the top half rotating with the auger, the bottom half stationary, the sealing action being where the two seal "faces" meet.

**Ice Sweep:** A plastic cap with "fingers". It revolves with the auger to "sweep" the ice into the ice chute.

**Divider:** Where the ice is compressed and much of the extra water is squeezed out of it before it is

**Motor:** A motor that drives the gear reducer.

**Bearing:** As the ice is pushed up the evaporator, the auger is thrust down, and pressure from the auger thrust is taken up by this bearing.

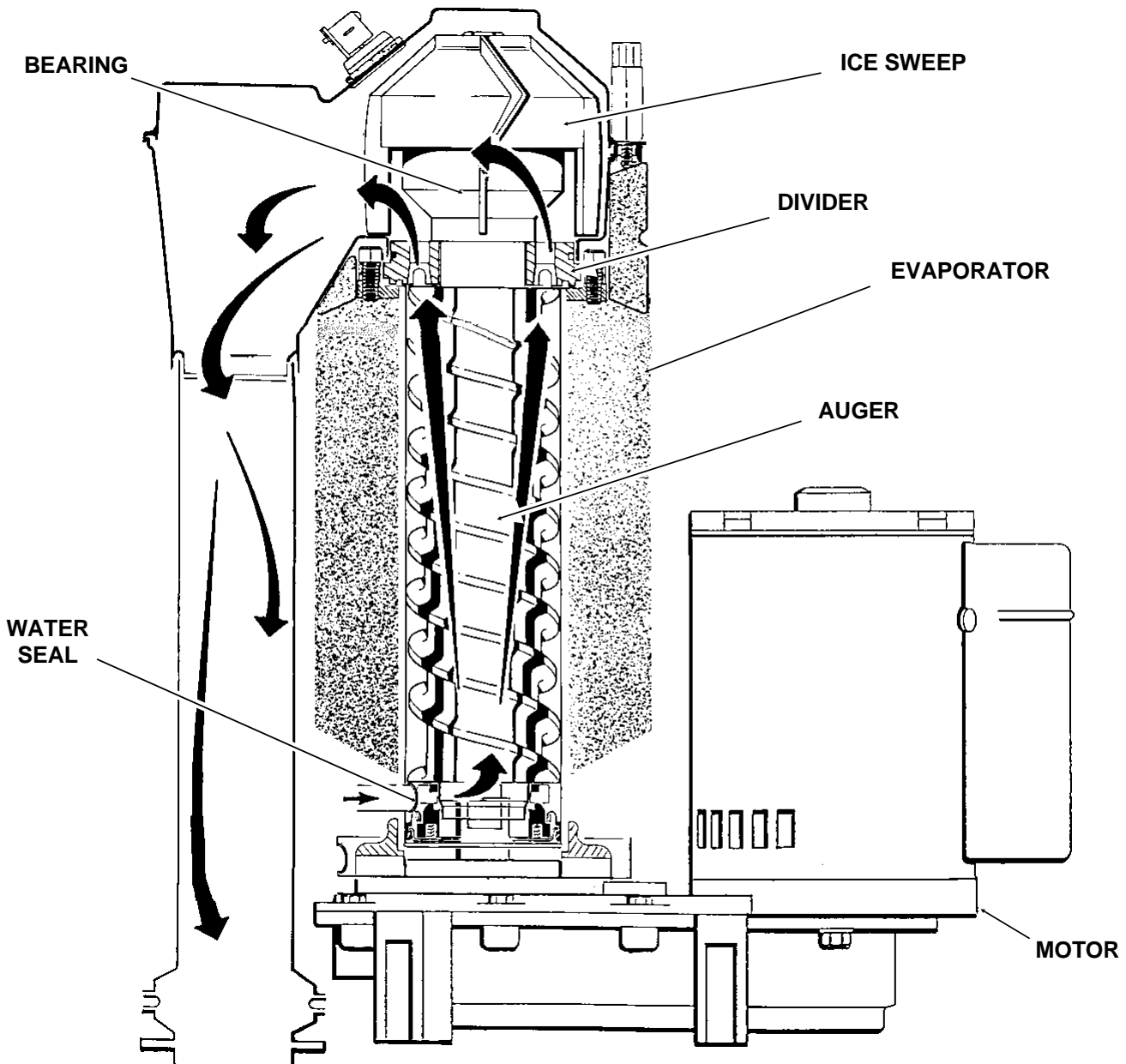

discharged into the bin.

## ELECTRICAL SEQUENCE

---

Refer the wiring diagram as needed.

### **Each system is separate**

If the machine is switched off at the master switch, but is otherwise ready to go, switching the master switch to on and pressing the start reset switch does the following:

- The bin empty light on the circuit board goes on
- There is a 15 second delay
- If there is enough water in the reservoir, the circuit board will allow the machine to start up.

### **Start up consists of:**

- The liquid line relay and auger motor relay become energized, connecting power to the windings of the auger motor.
- The auger motor starts, and the centrifugal switch closes, connecting power to the liquid line valve coil.
- The liquid line valve opens, and the refrigerant flows to the thermostatic expansion valve and into the evaporator.
- As ice goes past the ice level sensors, the bin empty light will stay on, and the machine will continue to run, unless the ice stays between the sensors for more than 15 seconds (bin full). At that point, the bin empty light goes out, and the machine shuts down.

### **Shut Down consists of:**

- The liquid line relay opens.
- The liquid line valve closes
- Ice making stops
- The auger motor is run by the circuit board for 2.5 more minutes, clearing out ice in the evaporator, and then
- The auger motor relay opens, and the auger motor stops.

If the ice level sensor is clear (bin empty) for more than 15 seconds, the machine will start up again.

Another purpose of the circuit board is to turn the machine off if there is not enough water in the machine.

- When the water level in the reservoir falls below the water level sensor, the machine will "shut down"
- When the water refills the reservoir, the machine will start up again.

Separate from the circuit board:

- If the spout switch opens, the machine will stop immediately (through the relays on the circuit board). It must be manually reset at the reset switch.
- The master switch is the manual control for each system, but it is not a service disconnect.

# FM2402RH

## OPERATION

### Water

Water enters the machine through the 3/8" male flare at the rear of the cabinet, goes to the water reservoir which it enters through the float valve. The water then goes out the bottom of the reservoir tank to the bottom of the evaporator. Reservoir overflow or evaporator condensation is routed to the drain.

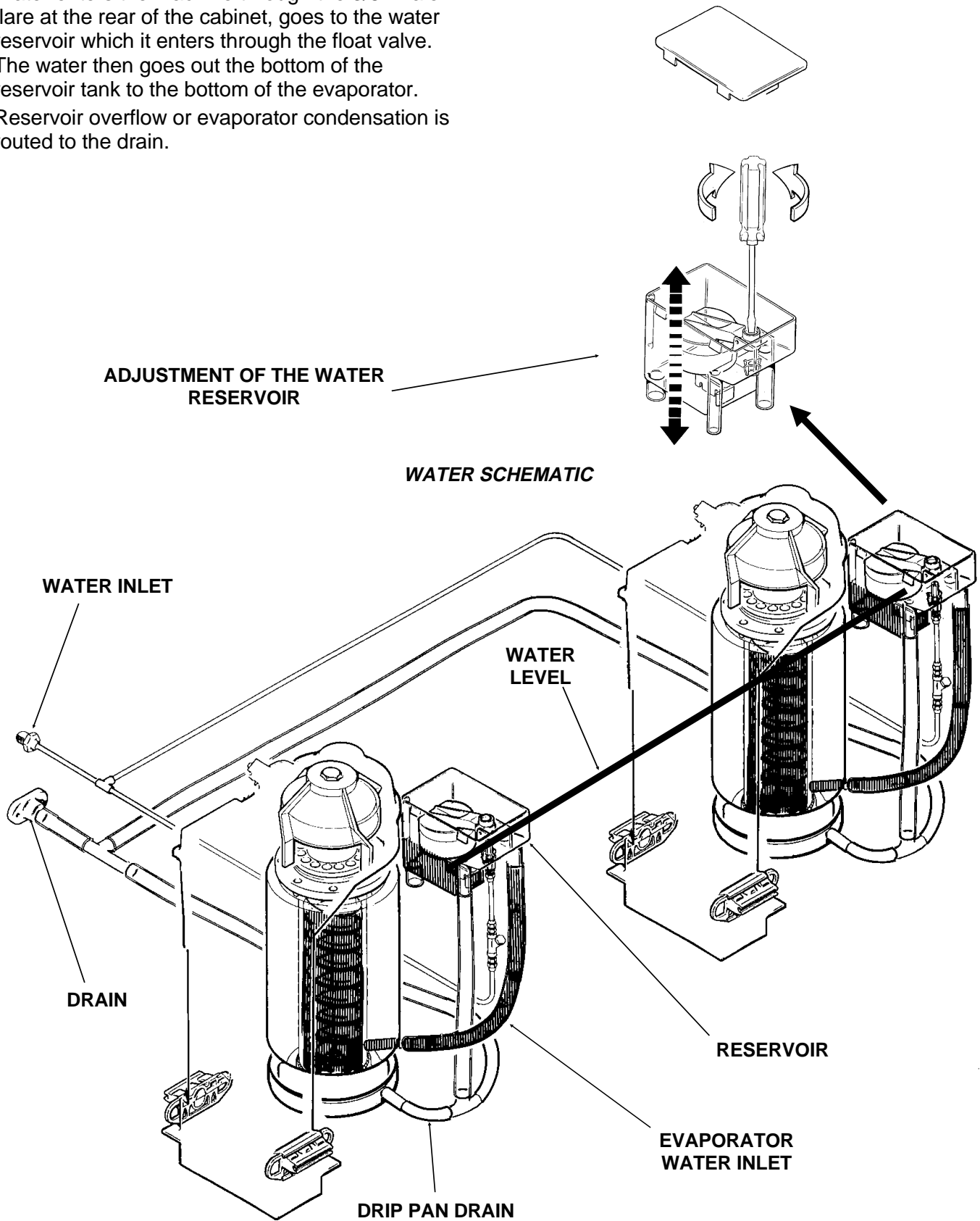

## OPERATION: Refrigeration

The remote high side supplies high pressure liquid R-22 to the liquid line connection on the ice machine. After the sight glass, there are two separate liquid lines, each leading to a liquid line valve. When the individual ice level sensor causes the circuit board to energize the liquid line valve, the valve opens, allowing the liquid refrigerant to enter that expansion valve. The thermostatic expansion valve meters the liquid refrigerant into

the evaporator, where it boils off (evaporates) and absorbs heat. It then moves through the ball valve and into the evaporator pressure regulator valve, or EPR. The EPR keeps the evaporator pressure above a predetermined point, even though the suction line pressure of the remote high side system may vary. The refrigerant, now a low pressure gas, moves into the suction line of the remote high side system.

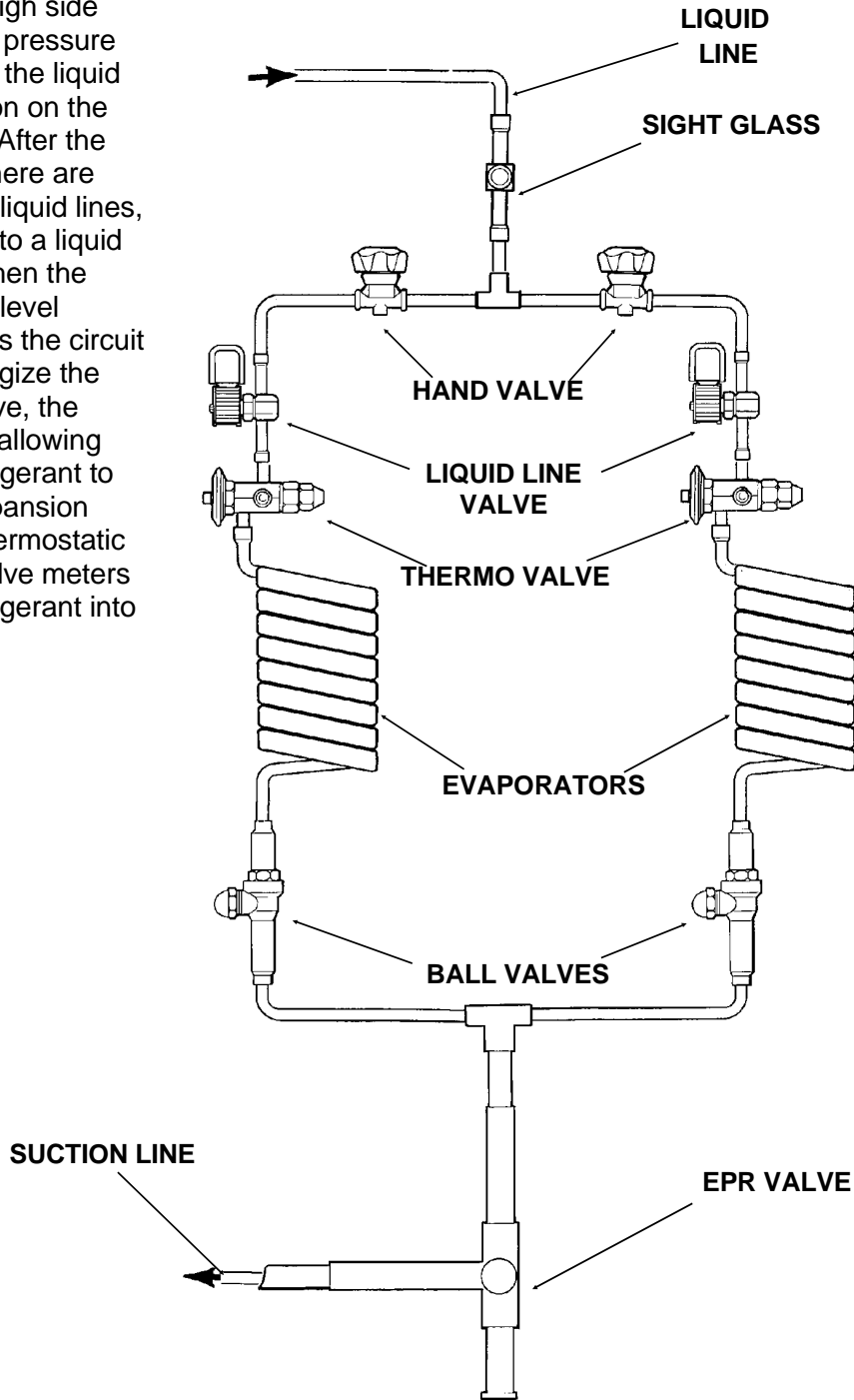

# FM2402RH

## MAINTENANCE AND CLEANING

---

////////////////////////////////////  
A Scotsman Ice System represents a sizable investment of time and money in any company's business. In order to receive the best return for that investment, it MUST receive periodic maintenance.

It is the USER'S RESPONSIBILITY to see that the unit is properly maintained. It is always preferable, and less costly in the long run, to avoid possible down time by keeping it clean; adjusting it as needed; and by replacing worn parts before they can cause failure. The following is a list of recommended maintenance that will help keep the machine running with a minimum of problems.

Maintenance and Cleaning should be scheduled at a minimum of twice per year.

////////////////////////////////////

**////////////////////////////////////WARNING////////////////////////////////////**

**Electrical power will be ON when doing in place cleaning. Switch it OFF before completing the cleaning procedures.**

**////////////////////////////////////**

**ICEMAKING SYSTEM: In place cleaning**

1. Check and clean any water treatment devices, if any are installed.
2. Pull out and remove the front panel.
3. Move the ON-OFF switch to OFF.
4. Remove all the ice from the storage bin.
5. Remove the cover to the water reservoir and block the float up.
6. Drain the water reservoir and freezer assembly using the drain tube attached to the freezer water inlet. Return the drain tube to its normal upright position and replace the end cap.

**////////////////////////////////////WARNING////////////////////////////////////**

**Scotsman Ice Machine Cleaner contains Phosphoric and Hydroxyacetic acids. These compounds are corrosive and may cause burns. If swallowed, DO NOT induce vomiting. Give large amounts of water or milk. Call Physician immediately. In case of external contact, flush with water. KEEP OUT OF THE REACH OF CHILDREN.**

**////////////////////////////////////**

7. Prepare the cleaning solution: Mix eight ounces of Scotsman Ice Machine Cleaner with three quarts of hot water. The water should be between 90-115 degrees F.
8. Slowly pour the cleaning solution into the water reservoir until it is full. Wait 15 minutes, then switch the master switch to ON.

9. As the ice maker begins to use water from the reservoir, continue to add more cleaning solution to maintain a full reservoir.
  10. After all of the cleaning solution has been added to the reservoir, and the reservoir is nearly empty, switch the master switch to OFF.
  11. After draining the reservoir, as in step 6, wash and rinse the water reservoir.
  12. Remove the block from the float in the water reservoir.
  13. Switch the master switch to ON
  14. Continue ice making for at least 15 minutes, to flush out any cleaning solution. Check ice for acid taste - continue icemaking until ice tastes sweet.
- ////////////////////////////////////WARNING////////////////////////////////////**
- DO NOT USE any ice produced from the cleaning solution.**
- Be sure no ice remains in the bin.**
- ////////////////////////////////////**
15. Remove all ice from the storage bin.
  16. Add warm water to the ice storage bin and thoroughly wash and rinse all surfaces within the bin.
  17. Sanitize the bin interior with an approved sanitizer using the directions for that sanitizer.
  18. Replace the front panel.

## MAINTENANCE

////////////////////WARNING////////////////////

**Disconnect electrical power before beginning.**

////////////////////

1. The bin control uses devices that sense light, therefore they must be kept clean enough so that they can "see". At least twice a year, remove the bin control sensors from the base of the ice chute, and wipe the inside clean, as illustrated.

2. The ice machine senses water level by a probe located in the water reservoir. At least twice a year, the probe should be removed from the

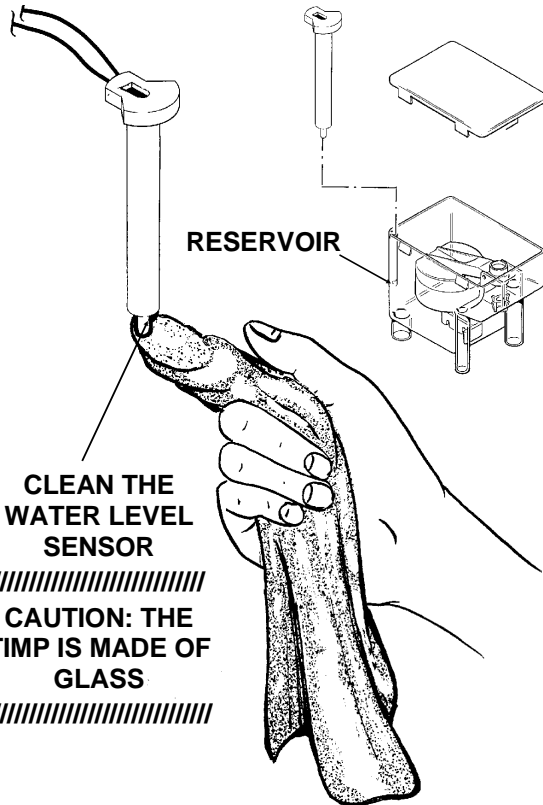

SLIDE ICE LEVEL CONTROLS OUT OF CHUTE

CLEAN THE ICE LEVEL CONTROL SENSORS

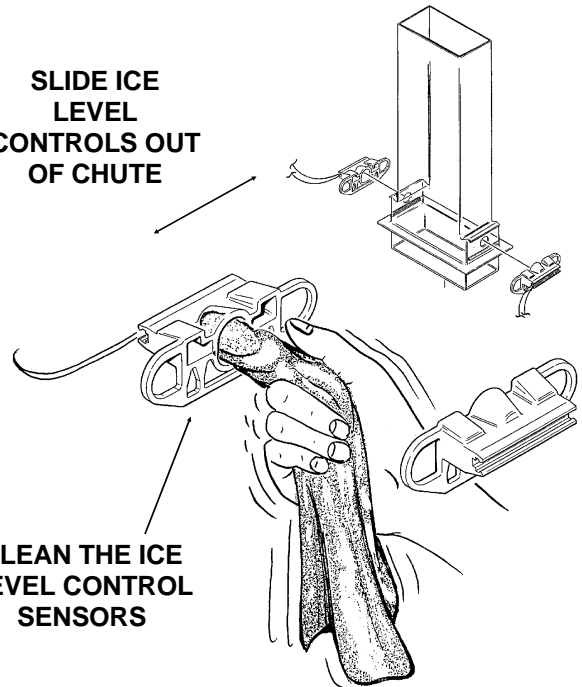

4. Check and tighten all bolts and screws.

reservoir, and the tip wiped clean of mineral buildup.

3. The bearing in the breaker should also be checked at least **two times per year**.

Check the bearing by:

- removing the ice chute cover
- unscrewing the ice sweep
- removing the water shed
- unscrewing the breaker cover
- unscrewing the auger stud

Inspect the assembly, looking for wear.

See Removal and Replacement to replace bearing or seals. Reverse to reassemble.

# FM2402RH

## CLEANING

In some installations the water supply to the icemaker will be so concentrated with dissolved minerals, (such as calcium carbonate) that as ice is made, the evaporator and auger become coated with the minerals, requiring a more frequent cleaning than twice per year. If in doubt about the condition of the evaporator and auger, the auger can be removed so the parts can be inspected.

Note: Water filters can filter out suspended solids, but not dissolved solids. "Soft" water may not be the complete answer. Check with a water treatment specialist regarding water treatment.

**Switch off electrical power, and shut off the water supply.**

**For more information on removal of these parts, see REMOVAL AND REPLACEMENT.**

1. To remove the auger, remove front and top panel. If top panel cannot be removed, or if there is less than 6" clearance over the top of the machine, the gearmotor/evaporator may be slid out for service access. See Removal And Replacement.
2. Remove 3 hex studs holding ice chute cover to ice chute, and remove cover.
3. Unscrew and remove ice sweep.
4. Loosen band clamp under ice chute, and remove ice chute from evaporator.
5. Remove 4 allen head screws holding breaker to evaporator.
6. Pull up on breaker to remove auger.

Allow the auger to dry, the stainless steel of the auger and evaporator **must** be clean and bright. Clean the auger and evaporator as required. **DO NOT HONE THE EVAPORATOR.**

7. Replace the water seal.
8. Reverse to reassemble.

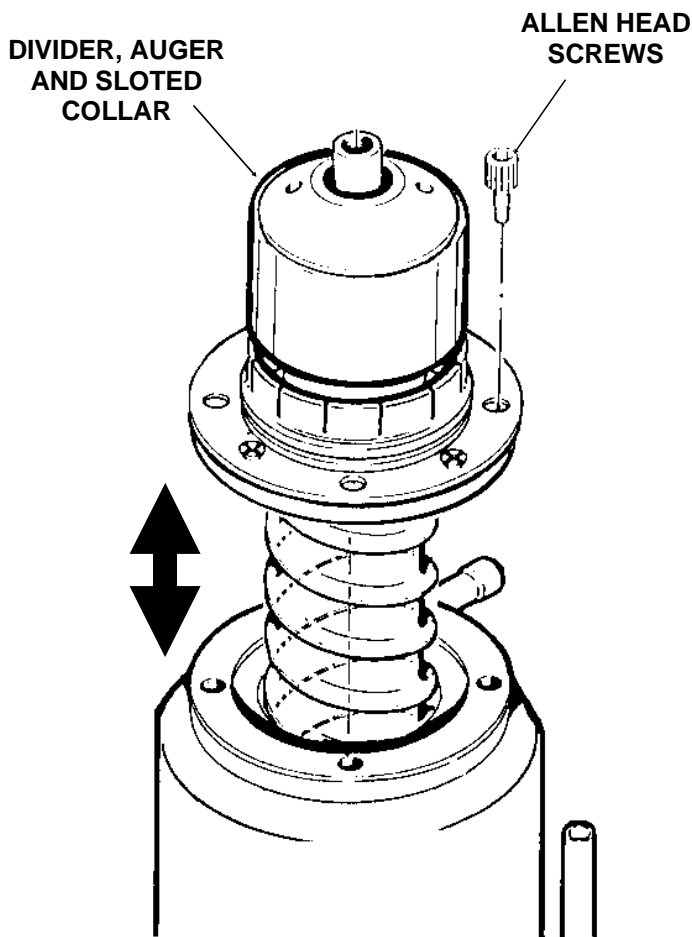



**SERVICE DIAGNOSIS: Condition - No Ice Being Produced**

---

**STATUS: *NOTHING OPERATES***

---

**A.** Check: **Voltage** to the unit, restore it if there is none. Compare to the nameplate.

---

**B.** Check: The **master switch**, switch ON if off.

---

**C.** Check the **spout switch**. It opens from excess pressure of ice inside the ice chute: this should only happen when the machine does not shut off when the ice storage bin is full. This switch must be manually reset.

---

**D.** Check the **water level** in the reservoir. The machine will not run if there is not enough water in the reservoir.

1. Restore/adjust water level. See the next step.

# FM2402RH

## SERVICE DIAGNOSIS: Condition - No Ice Being Produced

---

### STATUS: *NOTHING OPERATES*

---

F. Check: The gear **motor**, if it will not run, the liquid line valve will not open. If no power to it:

Check: The **indicator lights** on the circuit board, the **bin empty** light should be ON, the **no water** light should be OFF .

1. If the **bin empty** and **no water** lights are off, check the **transformer**.
  - a. Transformer "load" side should have 12 to 15 volts. If not, check the "line" side. The line side should have between 208-230 volts. If the line side has the correct voltage and the load side does not, replace the transformer.
2. If the transformer is good, and the **bin empty** light is OFF, check the **ice level sensors**.
  - a. Remove sensors by sliding them sideways out of the ice chute. Visually inspect them, clean if needed.
  - b. Look through the ice chute "eye" hole for something blocking the ice chute.
  - c. If the unit still does not run, replace the ice level sensors.
  - d. If the bin empty light is still OFF, check the **circuit board**.
    1. Unplug "opto trans" and "LED" connectors from the circuit board.
    2. Plug "opto trans" and "LED" connectors from the Scotsman Electronic Control Tester Model NM1 into the circuit board.
      - a. Move the "bin full" switch on the tester to the full position. The bin full light on the tester should be ON, if not, replace the circuit board.  
If the bin full light on the tester is ON, move the tester switch to "bin empty" the light on the tester should go OFF and the bin empty light on the circuit board should go ON. If not, replace the circuit board. If it does as above, and the machine still does not run, replace the ice level sensors.
3. If the transformer is fine, and the "no water" light is ON, check the **water level sensor**.
  - a. Check the water level in the **reservoir**, restore if low. If the water level is ok:
  - b. Remove the water level sensor from the reservoir and clean the tip if dirty.  
CAUTION: THE TIP IS MADE OF GLASS
  - c. Replace the water level sensor. If the no water light is still on, check that the "water sen" plug is firmly plugged into the circuit board.
  - d. If the no water light is still on,
    1. Unplug the "water sen" connector from the circuit board.
    2. Plug "water sen" connector from the Scotsman Electronic Control tester into the circuit board.
      - a. Move the water switch on the tester to "no water" and the no water light on the circuit board should go on. If not, replace the board.
      - b. Move the water switch to the "water" position, the no water light should go off, if not, replace the circuit board.
      - c. If after the above, the machine still will not run, replace the water level sensor

**SERVICE DIAGNOSIS:**

---

**STATUS: *GEARMOTOR OPERATES, BUT NO ICE IS MADE***

---

**A. Check the liquid line valve relay.**

The relay is on the circuit board, if it does not supply power to the liquid line valve, the valve will not open.

1. Check for power at the valve coil, if none:

**a.** Check for power at the liquid line valve relay at the circuit board.

    If there is power at the relay, but none at the liquid line valve coil,

        Check for an open wire between the relay and the valve.

2. Check the valve coil. If the coil is open, replace the liquid line valve.

3. Check the auger drive motor centrifugal switch. If, when the drive motor is running, contact 4 (black wire removed) has no power, and all of the above switches have been checked, replace the centrifugal switch, or the drive motor.

4. If the liquid line valve relay on the circuit board has power on the NO contact, but not on the COM contact, replace the circuit board.

# FM2402RH

## REMOVAL AND REPLACEMENT

### WATER RESERVOIR

1. Shut off the water supply to the icemaker.
2. Remove front panel and reservoir cover.
3. To remove float only, pry the mounting flanges apart enough to lift one float pivot pin out of the flange hole, and pull float up and out of the reservoir.
4. To remove reservoir, disconnect water inlet compression fitting at reservoir inlet.
5. Remove drain hose from reservoir.
6. Remove evaporator inlet hose from reservoir.
7. Remove mounting screws from reservoir bracket, and remove reservoir from icemaker.
8. Reverse to reassemble.

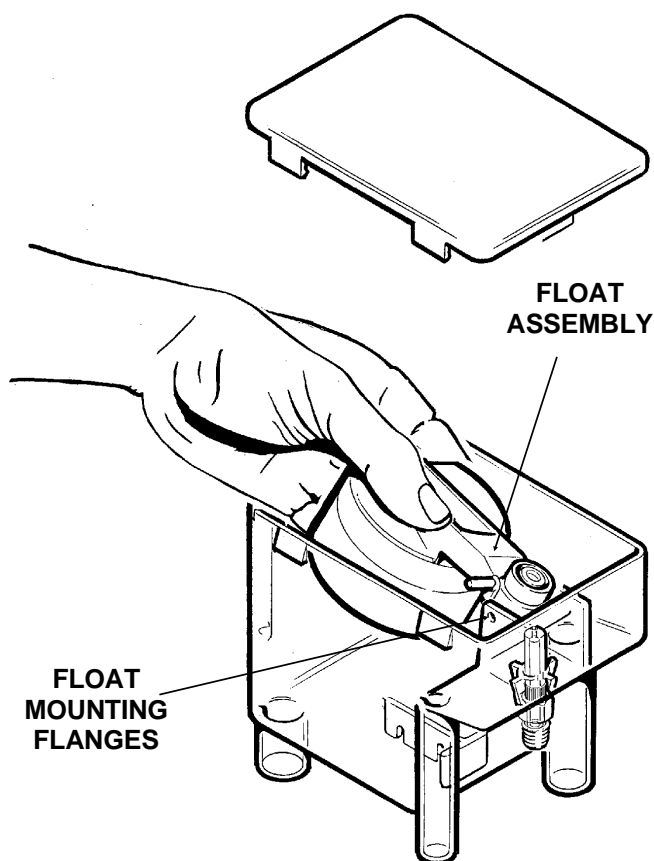

### BIN CONTROLS (Ice Level Sensors)

1. Disconnect electrical power.
2. Remove front panel.
3. Remove control box cover.
4. Locate ice chute, at the base of the chute, in front of and behind it are two plastic bin control mounts.
5. Slide each bin control to the left, and in the control box, disconnect the electrical leads connecting the bin control to the circuit board.
6. Reverse to reassemble, be certain that the bin controls are aligned so that the ice level sensors are visible (centered) through the holes in the cube chute.

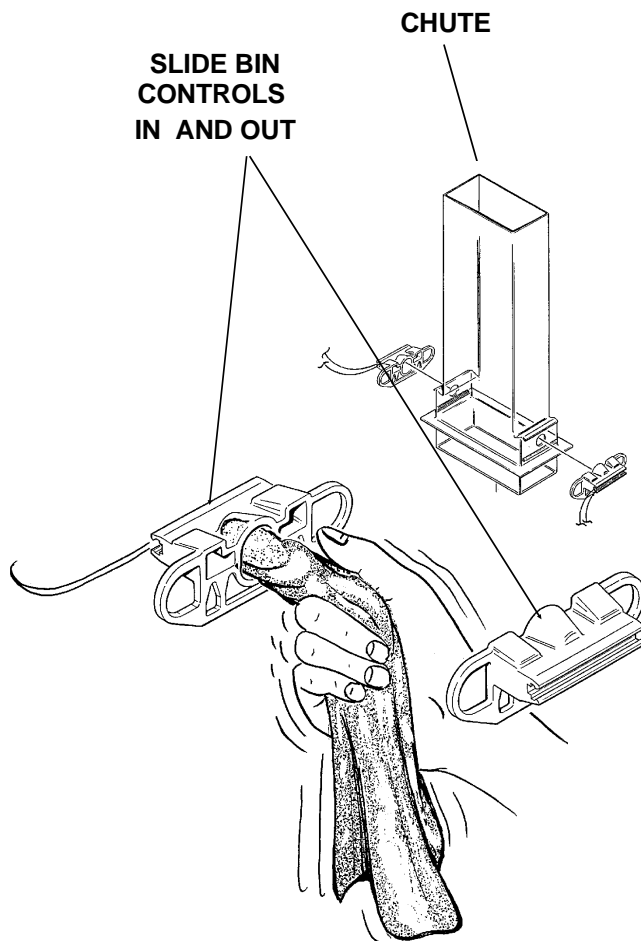

## REMOVAL AND REPLACEMENT: Bearing And Breaker

Note: Removal of the auger, water seal, evaporator and gearmotor must begin at the top of the assembly.

### To Remove the Breaker Bearing Assembly:

//////////////////////WARNING//////////////////////

**Disconnect the electrical power to the machine at the building source BEFORE proceeding with any repair.**

////////////////////////////////////

1. Remove panels and disconnect electrical power.
2. Unscrew three studs and remove ice chute cover.
3. Unscrew and remove ice sweep.
4. Remove insulation halves from outside of ice chute, loosen band clamp under ice chute, lift up and remove ice chute.
5. The breaker may be removed from the auger and evaporator without disturbing the auger.
  - a. Unscrew breaker cover from breaker (left hand threads)
  - b. Unscrew auger stud from top of auger.
  - c. Unscrew 4 allen head cap screws holding breaker to evaporator.
  - d. Lift up, and remove breaker/bearing assembly from auger & evaporator.

6. Service the bearing. Check for rust, rough spots and damage.

a. The bearing is pressed into the breaker, to remove the bearing and replace it an arbor press is needed.

b. Replace lower seals before installing new bearing in breaker.

Note: seals must be pressed in with a tool pushing against the outer edge only, they will not install by hand.

Replace parts as required. Re-grease bearing with Scotsman part no. 19-0609-01 bearing grease. Replace top seal, and check the o-rings, replace if cut or torn.

7. Reverse to reassemble: specific tools and materials are required to install properly.

a. Add food grade grease such as Scotsman part number 19-0569-01 to the seal area before installing on the auger.

b. Check the seal to shaft areas for cuts, or rough spots: none are permitted.

Step 5-b

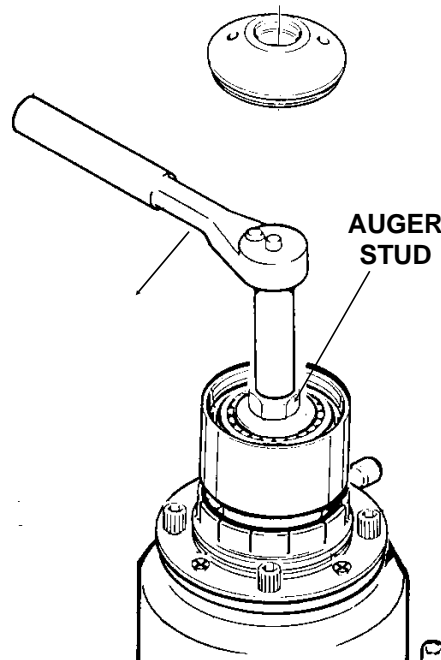

Step 5-c and Step 6

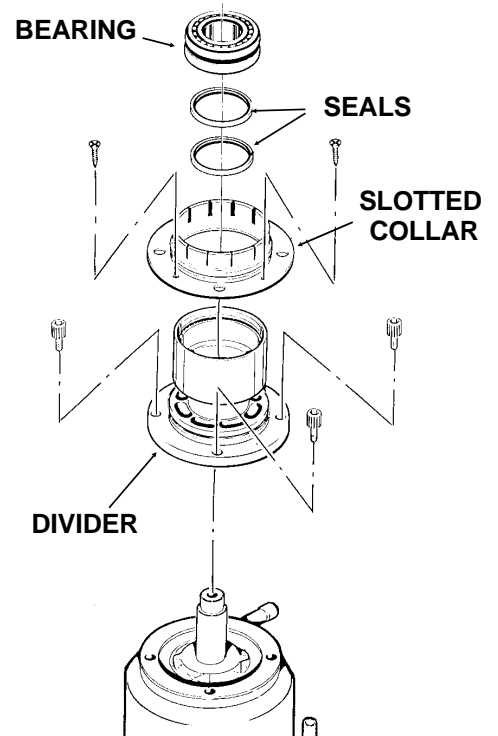

# FM2402RH

## REMOVAL AND REPLACEMENT

//////////////////WARNING//////////////////

**Disconnect electrical power. Handle the auger with care: it has sharp edges.**

//////////////////

### To Remove the Auger:

Turn off the water to the machine, and unclip the evaporator drain hose, pull it down and drain the evaporator into the bin or a container.

1. The top panel must be removed.
2. Remove ice chute cover.
3. Unscrew ice sweep.
4. Loosen band clamp and remove ice chute body.
5. The auger and breaker/bearing may now be removed as an assembly.
  - a. Unscrew 4 allen head cap screws holding breaker to evaporator.
  - b. Lift up on breaker and remove auger from evaporator.

*Note: If the auger is stuck, the breaker must be removed from the auger.*

The breaker may be removed from the auger and

Inspect the auger, the critical areas of the auger are:

1. The auger body. It should be clean and shining. Sometimes an auger will appear clean when wet, but after it is dry it will be seen to be stained. Scrub the auger with ice machine cleaner and hot water.

//////////////////WARNING//////////////////

Ice machine cleaner is an acid. Handle it with extreme care, keep out of the reach of children.

//////////////////

2. The water seal area. Because the auger has been removed, the water seal will have to be replaced. Remove the water seal top half from the auger, and inspect the auger for minerals clean as required.

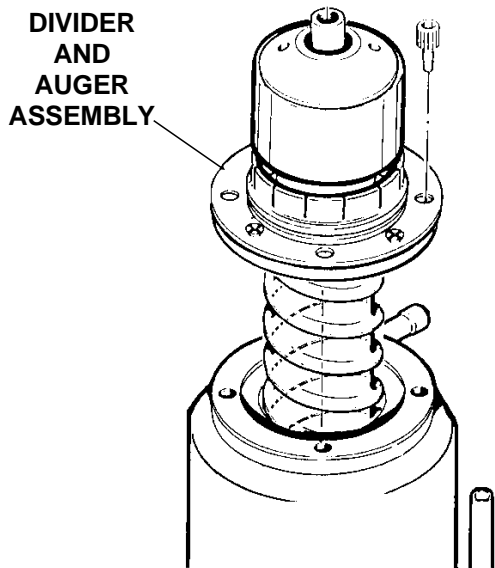

evaporator without disturbing the auger.

- a. Unscrew breaker cover from breaker (left hand threads)
- b. Unscrew auger stud from top of auger.
- c. Unscrew 4 allen head cap screws holding breaker to evaporator.
- d. Lift up and remove breaker from evaporator.
- e. If the auger is stuck use a slide hammer type puller to pull on the auger at the threaded hole. The size of that hole is 5/8"-18.

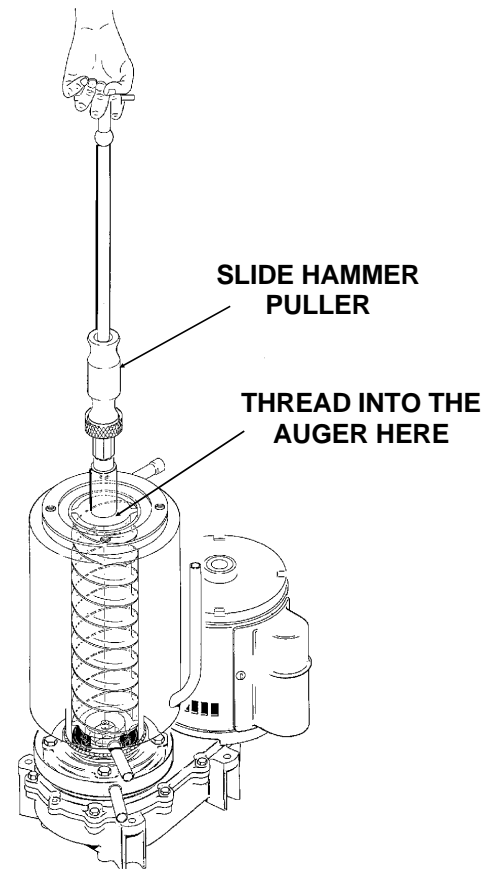

## REMOVAL AND REPLACEMENT

//////////////////**WARNING**//////////////////

**Disconnect the electrical power to the machine at the building source BEFORE proceeding with any repair.**

//////////////////

**To Remove the Water Seal:**

(Assuming all steps to remove the auger have been performed.)

1. The gearmotor/evaporator assembly will have to be exposed.
2. Remove the 4 hex head cap screws holding the evaporator to the gearmotor assembly. Lift the evaporator up and off of the gearmotor.
3. Remove the snap ring or wire retainer from the groove under the water seal.
4. Pull or drive out the lower half of the water seal.

**To Replace the Water Seal:**

1. Lubricate the water seal with water, and push the water seal into the bottom of the evaporator

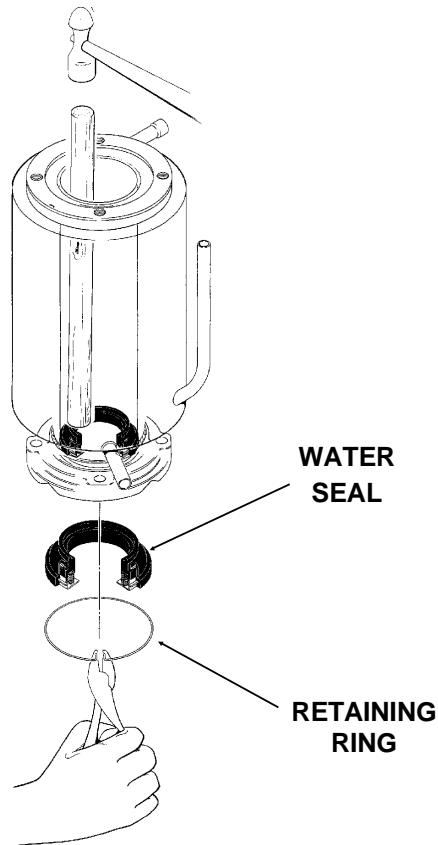

- slightly past the groove for the snap ring.
2. Replace the snap ring and pull the water seal down against it.
3. The part of the water seal that rotates with the auger must also be replaced. Remove the old part from the auger and clean the mounting area.

4. Place a small bead of food grade silastic sealant (such as 732 RTV or Scotsman part number 19-0529-01) on the area of the auger where the water seal is to be mounted.

5. Carefully push the water seal (rubber side against the auger shoulder and the silastic.)

//////////////////**CAUTION**//////////////////

Do not get any silastic onto the face of the seal.

//////////////////

6. Allow the auger and seal to air dry until the silastic is dry on the surface.
7. If the original water seal was leaking, it would be a good idea to inspect the interior of the gearmotor.

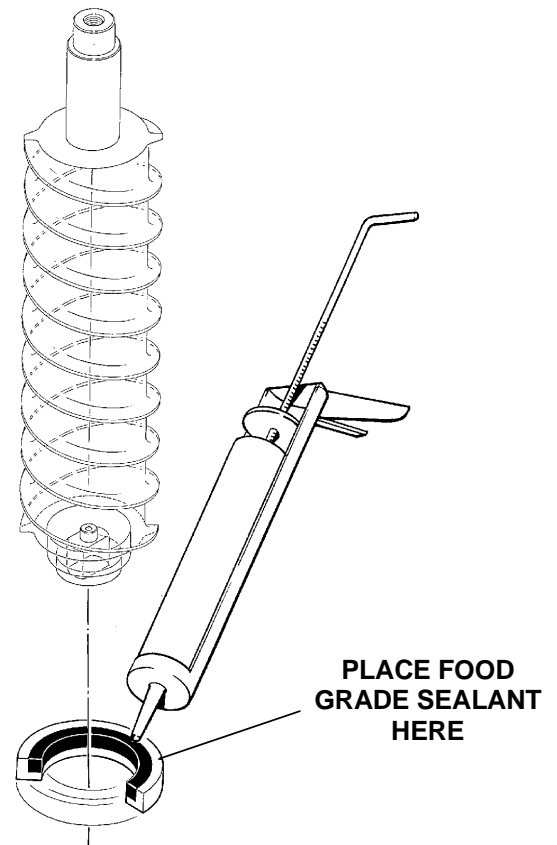

# FM2402RH

## REMOVAL AND REPLACEMENT: Evaporator

### To Replace the Evaporator:

(Assuming all the steps for removal of the thrust bearing, breaker, auger, and water seal have been performed.)

1. Shut the hand valves in the liquid and suction lines to the evaporator being serviced; then discharge the refrigerant.

2. Unswear the refrigerant connections:

a) At the thermostatic expansion valve outlet.

////////////////////CAUTION////////////////////

**Heat sink the TXV body when unswearing or resweating the adjacent tubing.**

////////////////////

b) At the suction line at the joint about 3" from the evaporator.

3. Remove the evaporator.

4. Unswear the drier from the liquid line.

5. After installing a new water seal in the new evaporator (see "To Replace the Water Seal") sweat in the new evaporator at the old connections.

6. Install an new drier in the liquid line.

7. Evacuate the system until dehydrated, then weigh in the nameplate charge. Check for leaks.

8. Install auger, breaker, breaker bearing assembly, and ice discharge chute in reverse order of disassembly. See "To Reassemble Evaporator and Auger"

### To Reassemble the Evaporator and Auger

1. After the gearmotor has been inspected, fasten the evaporator to the gear motor, be sure that the number of shims indicated on the gear case cover is in place between the gearcase cover and the drip pan gasket. Torque the bolts to 110 inch pounds.

2. Lower the auger into the evaporator barrel, slightly turning it to match up with the drive end. Do Not Drop Into the Evaporator.

3. Complete the reassembly by reversing the disassembly for the breaker & thrust bearing assembly.

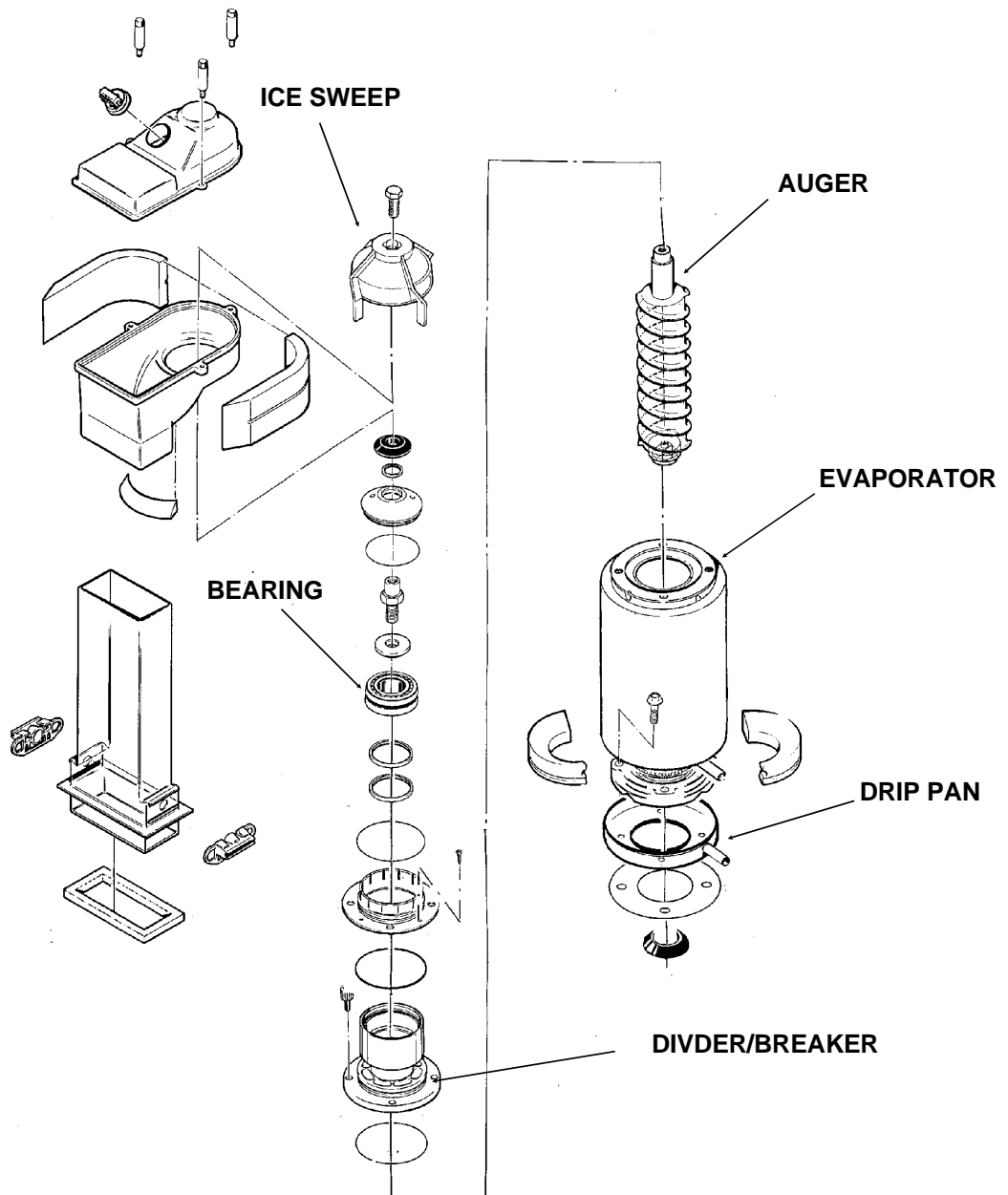



## **REMOVAL AND REPLACEMENT: Gearmotor**

---

### **To Remove and Repair the Gearmotor**

#### **Assembly:**

(Assuming that the procedures through removal of the water seal have been performed.)

1. Remove the electrical wires from the gear drive motor.
2. Unscrew the 4 cap screws holding the gearmotor to the gearmotor plate.
3. Remove the gearmotor from the icemaker.

# FM2402RH

## CIRCUIT BOARD TESTING

//////////////////////WARNING//////////////////////////////////////

These procedures require the machine to be connected to the power supply. The voltages of the electronic circuit are very low, but HIGHER VOLTAGES ARE PRESENT IN THE UNIT. Do not touch anything but the tester while the unit is being checked out. Make all connections to the circuit board with the ELECTRICAL POWER OFF.

//////////////////////////////////////

### INSTRUCTIONS FOR USING TESTER, model FC1 (Optional, order part no. A33942-001)

(These instructions assume that the unit **will not run**, and prior investigation of electric power, controls, and mechanical parts indicates that the electronic circuit may be at fault.)

If the "NO WATER" indicator is lit, but inspection shows that the water level in the reservoir is above the top of the water level sensor, OR the "BIN EMPTY" indicator is off while inspection shows that the ice level sensors are properly aligned, clean and not obstructed, use the tester as follows:

**Bin Control** *Note: All testing is done with the electrical power on, the master switch on, and all reset switches "reset".*

1. Unplug "photo trans" and "LED" connectors from the circuit board.
2. Plug "photo trans" and "LED" connectors from the tester into the circuit board.
  - a. Move the "bin full" switch on the tester to Full. The light on the tester should be ON.

If the light on the tester is not on, the circuit board should be replaced.

- b. If the light on the tester IS on, move the "bin full" switch to Bin Empty. The light on the tester should go OFF, and the Bin Empty light on the circuit board should go ON.

If the Bin Empty light is ON, wait 10-20 seconds for the machine to start, if the machine starts, replace the ice level sensors.

If the Bin Empty light does not come ON, the circuit board should be replaced.

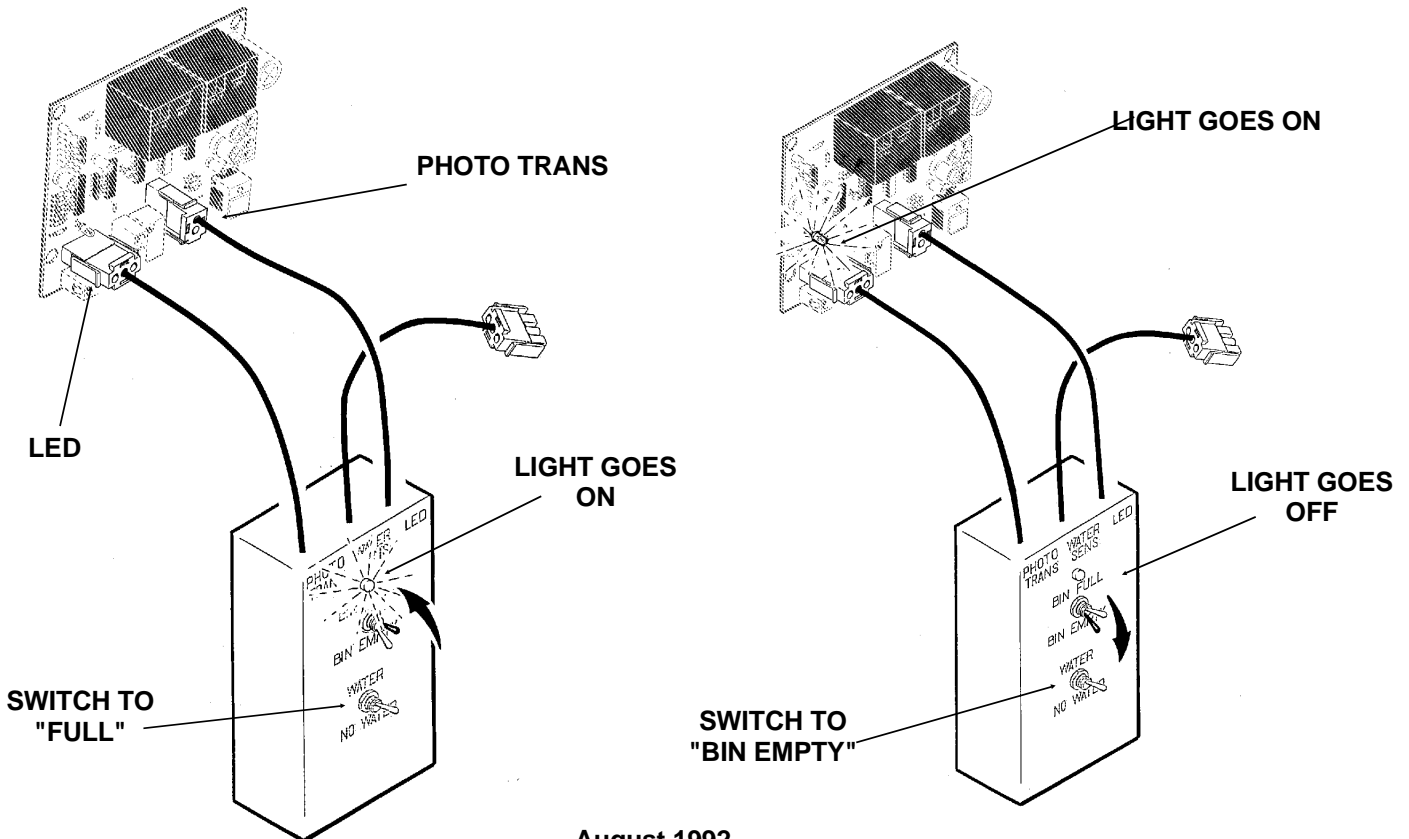

## CIRCUIT BOARD TESTING

### Water Level

1. Unplug "water sen" connector from control board.
2. Plug "water sen" connector from Scotsman tester into circuit board.
  - a. Move "water" switch on tester to No Water position. The No Water light on the circuit board should go ON. If not, replace the circuit board.

- b. Move the "water" switch on the tester to the Water position. The No Water light on the board should go OFF. If not replace the circuit board. If the light does go off, replace the water level sensor. If the Bin Empty light is ON, wait 10-20 seconds for the machine to start. The machine should start.

